

# SET-UP SHEET

# XRAY T3.11

RACE	LRP Touring Car Masters		
TRACK	LRP TCM		
NAME	Eric Dankel		
CITY / COUNTRY	Neckarsulm	Germany	
CONTACT	eric.dankel@web.de		

DATE	28/03/2011	TEMPERATURE / °F or °C	AIR	25	TRACK	-	
QUALIFYING POSITION	1	BEST LAPTIME / sec	13,9	FINAL POSITION	1	RACE LENGTH / minutes	5

TRACK CONDITION	<input type="checkbox"/> TECHNICAL	<input checked="" type="checkbox"/> CARPET	<input type="checkbox"/> ASPHALT
	<input type="checkbox"/> LOW	<input type="checkbox"/> MIXED	<input type="checkbox"/> FAST
TRACTION	<input type="checkbox"/> LOW	<input type="checkbox"/> MEDIUM	<input checked="" type="checkbox"/> HIGH

FRONT	REAR
TRANSMISSION	

FRONT PULLEY	38	38	REAR PULLEY
DIFF.			
LOOSE	<input type="checkbox"/>	MEDIUM	<input type="checkbox"/>
TIGHT	<input type="checkbox"/>	TIGHT	<input checked="" type="checkbox"/>
ONE WAY DIFFERENTIAL	<input type="checkbox"/> YES		
SOLID ONE WAY DIFF.	<input type="checkbox"/> YES	MIDDLE ONE WAY PULLEY	
SOLID AXLE	<input checked="" type="checkbox"/> YES	FIXED	<input checked="" type="checkbox"/>
		ONE-WAY	<input type="checkbox"/>

PINION / T	41	SPUR GEAR / T	108
FINAL DRIVE RATIO	2.6341463414634	ROLLOUT	NaN

FRONT	REAR
<input checked="" type="checkbox"/> ALU	<input type="checkbox"/> PLASTIC
SHOCKS	
<input checked="" type="checkbox"/> ALU	<input type="checkbox"/> PLASTIC
XRAY SPRINGS	
#308393 Super Soft	<input type="checkbox"/> YELLOW (D=1.4) 14 lb
#308384	<input type="checkbox"/> BLUE-GREEN (D=1.5) 15 lb
#308394 Soft	<input type="checkbox"/> WHITE (D=1.5) 17.5 lb
#308385	<input type="checkbox"/> LIGHT-BLUE (D=1.6) 20 lb
#308395 Soft Medium	<input type="checkbox"/> BLUE (D=1.6) 22.5 lb
#308386	<input type="checkbox"/> DARK-BLUE (D=1.7) 25 lb
#308396 Medium	<input type="checkbox"/> VIOLET (D=1.7) 28 lb
#308387	<input type="checkbox"/> LIGHT-PURPLE (D=1.8) 30 lb
#308397 Medium Hard	<input type="checkbox"/> PURPLE (D=1.8) 33 lb
#308388	<input type="checkbox"/> LIGHT-RED (D=1.9) 35 lb
#308398	<input type="checkbox"/> RED (D=1.9) 38 lb

#308373	<input type="checkbox"/> C 2.2	<input type="checkbox"/>
#308374	<input type="checkbox"/> C 2.4	<input type="checkbox"/>
#308375	<input type="checkbox"/> C 2.6	<input checked="" type="checkbox"/>
#308376	<input checked="" type="checkbox"/> C 2.8	<input type="checkbox"/>
#308377	<input type="checkbox"/> C 3.0	<input type="checkbox"/>
#308378	<input type="checkbox"/> C 3.2	<input type="checkbox"/>
#308379	<input type="checkbox"/> C 3.4	<input type="checkbox"/>

550	OTHER SPRING	550
	OIL / CST	
	LENGTH / mm	
	PRELOAD / mm	
0	REBOUND %	0
<input type="checkbox"/> YES	<input checked="" type="checkbox"/> NO	<input type="checkbox"/> YES
<input type="checkbox"/> YES	<input checked="" type="checkbox"/> NO	<input checked="" type="checkbox"/> NO
<input type="checkbox"/> YES	<input checked="" type="checkbox"/> NO	<input type="checkbox"/> YES
<input type="checkbox"/> YES	<input checked="" type="checkbox"/> NO	<input checked="" type="checkbox"/> NO

<input type="radio"/> OPENED	<input checked="" type="radio"/> CLOSED	HOLES IN PISTON
------------------------------	---	-----------------

1,4	THICKNESS / mm	ANTI-ROLL BAR	THICKNESS / mm	1,3
-----	----------------	---------------	----------------	-----

CPX	TIRES	CPX	
	DIAMETER / mm		
LRP	INSERTS	LRP	
LRP	ADDITIVE	LRP	
FRONT LEFT	FRONT RIGHT	REAR LEFT	REAR RIGHT
TREATED AREA			

WHEELS		
S <input type="checkbox"/> M <input type="checkbox"/> H <input checked="" type="checkbox"/>	HARDNESS	S <input type="checkbox"/> M <input type="checkbox"/> H <input checked="" type="checkbox"/>

MOTOR	x12	TIMING	0000
ROTOR	standart	ARMATURE	13.5

ESC	SXX S.S V2	BATTERIES	LRP 6200
BRUSHLESS	PROGRAM	PUNCH	INITIAL BRAKE
			AUTO BRAKE

BODY	Mazda Speed 6	WING	PF
------	---------------	------	----

●  - APPLIED S-SOFT M-MEDIUM H-HARD

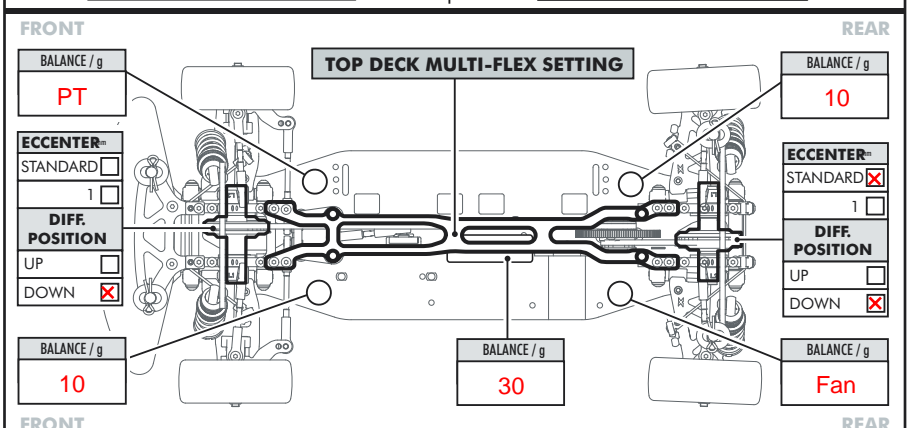
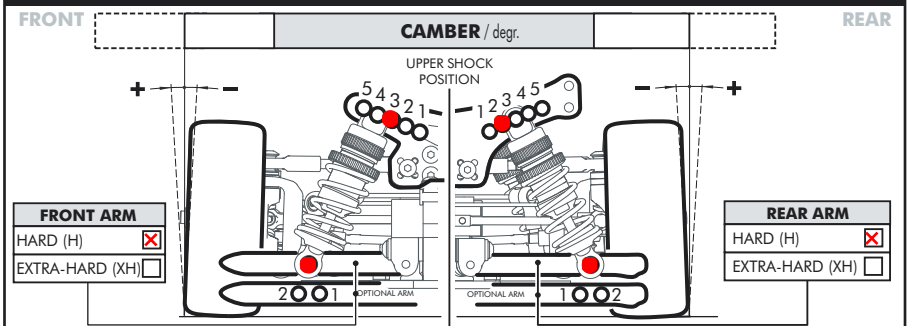
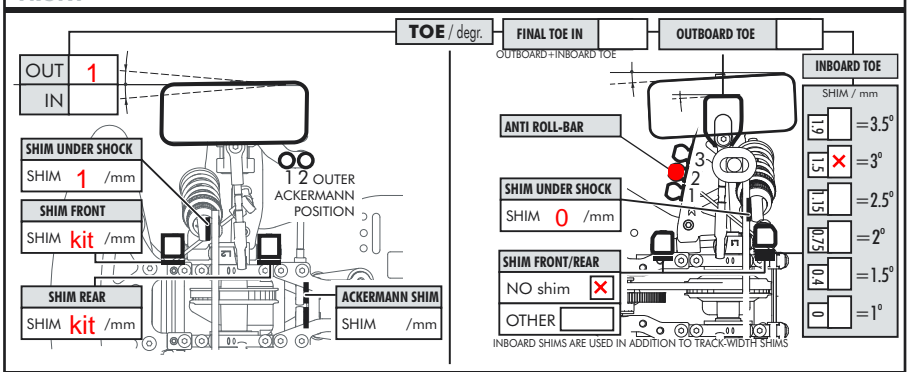
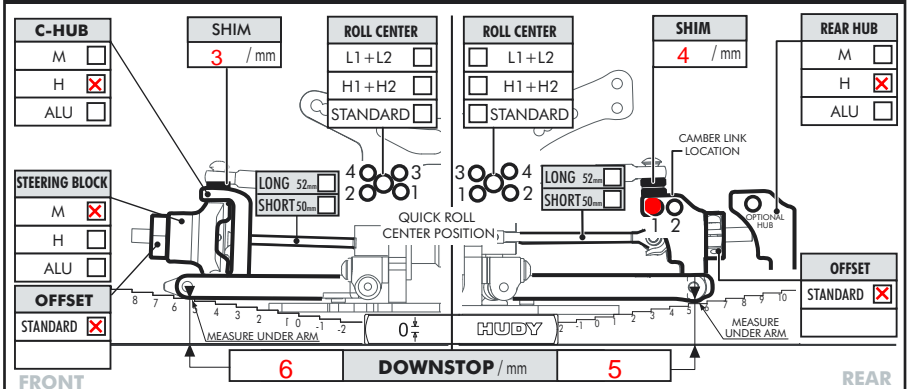
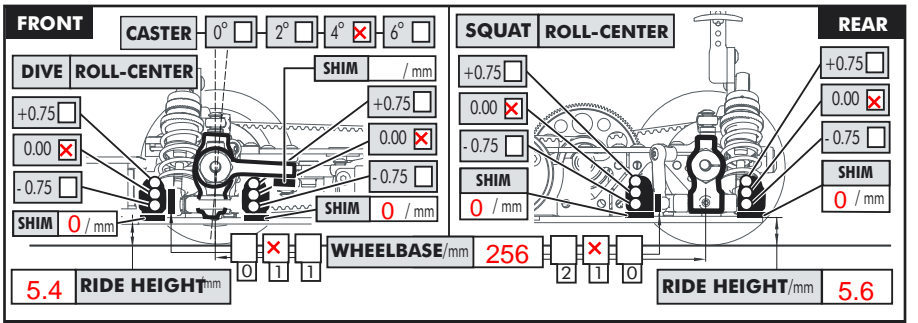

New #302028-O upper bulkhead clamps.  
 Front and rear middle position.  
 Rear gear diff fluid 1000Cst.